

# Hybrid Yard Tractor Development & Demonstration – Beta Test

Technology Manufacturer  
US Hybrid

Co-Participants  
Port of Long Beach, Port of Los Angeles, Long Beach Container Terminal

## Project Objective

As a follow-on Hybrid Yard Tractor Development & Demonstration Project conducted in 2010, the Port of Long Beach, Port of Los Angeles, US Hybrid and Long Beach Container Terminal assessed the potential in-use fuel economy performance of newly modified hybrid yard hostlers from February to June 2011 under a new project, Hybrid Yard Tractor Development & Demonstration – Beta Test.

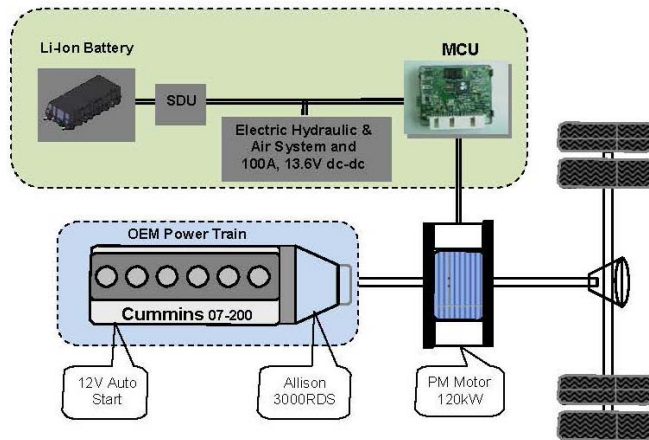

For the majority of the demonstration period, LBCT had use of only one US Hybrid yard hostler. Ship service provided the greatest amount of vehicle operation and fuel consumption data possible, relative to the other two service types, therefore LBCT elected to use the US Hybrid yard hostler in ship service. Late in the demonstration, a second US Hybrid unit was made available to LBCT and this unit was placed into rail service.

## Technology Description

The hybrid yard hostlers demonstrated consist of standard Kalmar Ottawa yard hostlers fitted with a parallel hybrid-electric power trains. Following the initial demonstration of the hybrid yard hostlers in 2010, US Hybrid made modifications to the hybrid system to improve fuel economy from the previous demonstration. In particular, US Hybrid altered the battery management algorithm, hybrid control algorithm, idle management strategy, and increased the capacity of the traction battery. These modifications resulted in a Generation 1.1 configuration. Near the end of the current demonstration, US Hybrid provided a second unit to LBCT that incorporated several additional modifications, including changes to the transmission control algorithm, electric motor, and motor control unit. This configuration is referred to as Generation 2.0.

## Results

The results of the analysis support the following conclusions:

1. Based on the iDrive data acquisition system and paper fuel logs completed by LBCT, the Generation 1.1 yard hostler placed into service at LBCT did not demonstrate significantly

different fuel economy compared to either the baseline yard hostler or the Generation 1.0 hybrid yard hostler tested during the previous demonstration.

2. Because the Generation 2.0 yard hostler was placed into service close to the end of the demonstration period, there was insufficient fuel consumption data collected to make any conclusions regarding its fuel economy.
3. Generation 2.0 yard hostlers have been redesigned to address the fuel economy performance issues encountered in the previous demonstration. The consistency of fuel consumption data and the high level of use of tractors in service make this the preferred service to demonstrate the Generation 2.0 or future generation hybrid yard hostlers.

Following the completion of the project, the hybrid systems were removed and the vehicles returned to their original state by Kalmar. Further demonstration of the hybrid drive technology in yard hostlers continues in a separate parallel project conducted by the New York Power Authority and the Port Authority of New York/New Jersey. Three of the newer generation hybrid yard hostlers have been operating in day-to-day terminal operations at New York Container Terminal since 2010. Similar to the project conducted at LBCT, the hybrid vehicles' in-use performance and fuel economy is being assessed. In addition, chassis dynamometer emissions testing will be conducted. The TAP will continue to monitor the progress of the project.



### **Project Costs**

The total cost of the supplemental demonstration was \$26,000 which was split evenly between the two Ports (or \$13,000/port).

### **Contact Information**

Abas Goodarzi, Ph.D., P.E.  
President, CEO  
US Hybrid Corporation  
445 Maple Ave., Torrance, CA 90503-3807  
Tel: 310-212-1200 Ext: 111, Fax: 310-212-1102  
[abas@ushybrid.com](mailto:abas@ushybrid.com)  
[www.ushybrid.com](http://www.ushybrid.com)

Updated: April, 2011